

## KA612 Programming Instructions



KA612 is a vandal resistant proximity card and keypad access control unit suitable for external applications. The unit accepts up to users and provides entry via the use of proximity cards and/or pin codes.

### Equipment provided

The following is provided as part of every KA612 package:

- KA612 Access Control Unit
- Installation Kit
- Installation and Operating Instructions

### Additional Equipment Required

- Electric lock Strike Mechanism  
Fail Safe (power to lock) or Fail Secure (power to open)
- Power Supply with Backup Battery  
12VDC (From a Regulated Power Supply)
- Request to Exit (REX) Button  
Normally Open Type-Switch is closed when pressed.

### Technical Specification

- Electrical Characteristics  
Operating Voltage:  
> 12VDC From a Regulated Power Supply  
Input current:  
> Standby: 40mA Not including attached devices  
> Max: 130mA Not including attached devices  
Outputs:  
> Lock Strike Relay From C, 5A  
> Auxiliary Relay From C, 5A  
> LockStrike Control Output  
Collector Open Output (25mA)  
> Auxiliary Control Output  
Collector Open Output (25mA)
- Inputs:

- > REX N.O.,Dry Contact
- > Auxiliary Input(In/Monitor) N.C.,Dry Contact in  
Monitor Mode N.O.,Dry Contact Input Mode

- Built-in Proximity reader
    - > Read Range 65mm
    - > Modulation ASK at 125kHz
    - > Compatible Cards ALL 26-Bit EM Cards
  - Environmental Characteristics
    - > Operating Temperature: 0 to 5%(Non-Condensing)  
Suitable for outdoor use
  - Mechanical Characteristics
    - > Dimensions:120L\*76W\*27Hmm
    - > Weight:0.9lbs(410g)
- Range also depends on electrical environment and proximity to metal.

### Key Features

Here are some of the KA612's key features:

- Built-in Proximity Card Reader(125KHZ ASK Modulation)
- Built-in Keypad for PIN Code entry
- Auxiliary Input & Auxiliary Output
- Eight Auxiliary Modes including:
  - > Door Ajar
  - > Forced Door
  - > Shunt
  - > Door Monitor
  - > Normal/Secure
- Internal Buzzer
- Two Status/Programming Interface LED'S
- Two Modes of Operation
  - > Normal Mode
  - > Secure Mode
- Three User Levels
  - > Normal User
  - > Secure User
  - > Master User
- Four Open door mode
  - > 4 digit Pin Code
  - > 4 digit Pin Code & EM Card
  - > 4 digit Pin Code & 1.4 digit Pin Code
  - > EM Card & EM Card

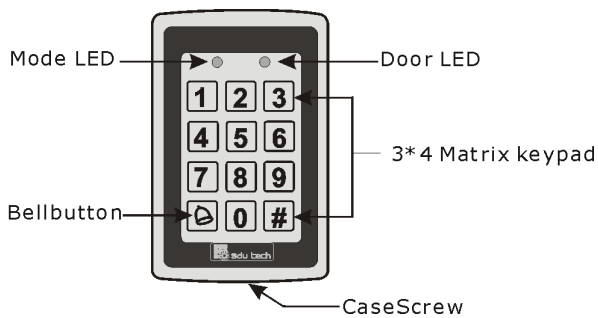

### Construction

- code search Feature that helps make maintaining user codes easier.
- Built-in Case and Back Tamper  
Bell, Chime, Siren, Battery Backup, Tamper Output features available with IBA Power Supplies.
- Programmable Siren Time.
- Programmable Lock Strike Release Time.

### Mounting the KA612 Controller

- 1) Before starting, select the location to mount the KA612 Controller. This location should be at shoulder height and on the same side as the door handled.
- 2) Drill holes into the back of the metal according to how you want to mount the KA612 Controller. (See explanation and diagram below).

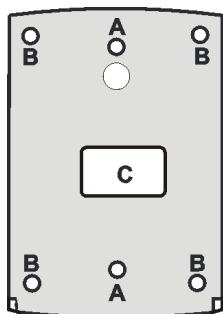

- > A. Mounting hole
- > B. 4 blind holes for Auxiliary Installation

- 3) Drill the exit/entry holes for the wiring. (Shown marked as C)
- 4) Pass the wires through the exit/entry holes and attach them to the controller corresponding terminal blocks as shown in the below diagram.

Connecting the wires to the corresponding terminal blocks

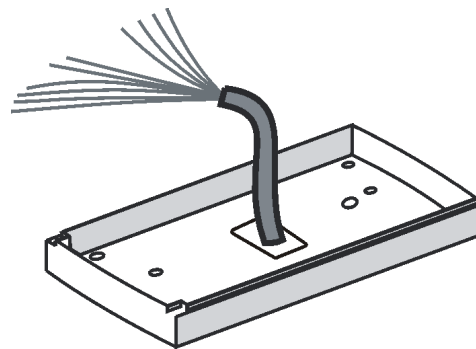

- 5) Screw the KA612 Controller back cover to its mounting location.
- 6) Return the front cover by using the supplied security screw in the controllers accessories kit. An L-Shapped tool is provided for use when tightening the security screw.

### Wiring Instruction

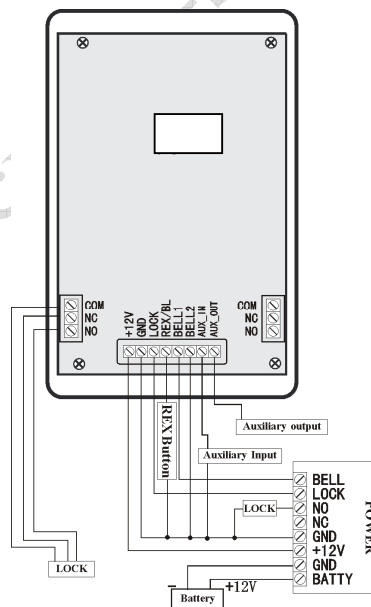

### Operation Introduction

#### Normal, Secure, & Master Users

The KA612 accepts up to 500 users and provide entry via two codes: Memory Slot 1(Primary code) and Memory Slot 2(Secondary code).

- There are three user levels:
  - > **Normal User**

A Normal User only has a Primary Code and is only granted access when the IBA-761 is in Normal Mode.

> **Secure User**

A Secure User must have a Primary and Secondary code programmed, the two codes must not be the same. The Secure User can gain access when KA612 is in its two Modes of Operation. In normal Mode the Secure User must present both their Primary and Secondary Codes in order to gain entry.

> **Master User**

A Master User must have both Primary and Secondary code programmed with the same Proximity Card or PIN code. The Master user can gain access during any Mode of Operation by presenting their Proximity Card or PIN CODE to the controller. (The master user is convenient but is less secure than a Secure User).

- Primary code and Secondary code  
Primary code:
  - 1) Only can be used separately under the mode of Normal
  - 2) Can't be same with the other codes
- Secondary code:
  - 1) Must match the corresponding Primary Code in Secure Mode
  - 2) Don't be same with the System Code (i.e. Factory settings), but the different users can set the same
- Secondary code.  
Normal Mode and Secure Mode

1) Normal Mode:

Normal Mode is the Default Factory Setting Mode, all the normal users, secure users and master users can entry with Primary code or EM Card.

2) Secure Mode

Only secure users and master users can entry can entry in this mode. The secure users enter the Primary and Secondary Code to entry, but the time interval should be less than 10 seconds. The master users can entry either primary code or secondary code (EM card).

- Changing from Normal Mode to Secure Mode  
Press # for 2 seconds, enter the Secure Mode, Press #
- Changing from Secure Mode to Normal Mode  
Press # for 2 seconds, enter the Secure Mode, Press #  
Reference: The default factory setting for the Program Code is 3-8-3-8

**Programming Introduction**

You can enter the Programme mode only when you are under the Normal mode

How to enter the Programme mode

- 1) Press # for 2 seconds
- 2) Enter your 4-digit programme code

**programming Menu**

Menu Number	Menu Description	Factory Settings
1	Chang Open Code	2580
2	Chang Auxiliary Code	0852
3	Chang Program Code	1234
4	Chang Secure Code	3838
6	Chang Door Release Time	0004
7	Define Auxiliary Input/outputs Enroll Proximity Cards, PIN Code or both	
8	Delete Proximity Cards Or PIN Code	
9	Code Assignment with Strike/Auxiliary	
0	Return to Default Factory Setting	

- Exit Programme mode  
Press # for 2 seconds (The door LED will be off, The Mode

LED will turn green)

NOTE: The display Led light will have different change if you

press different keys .

i.e

Press "1" the Mode LED will turn red and Door LED will turn green.

Press "2" the Mode LED will turn orange and Door LED will turn green.

Press "3" the Mode LED and Door LED all will turn green.

Press "4" the Mode LED will flash red and Door LED will turn green.

Press "6" the Mode LED and Door LED all will turn green.

Press "7" the Mode LED will turn down and Door LED will turn orange.

Press "8" the Mode LED will turn red and Door LED will turn orange.

Change the System code

- Change the Open door code

- 1) Enter Program mode
- 2) Press 1 to enter menu 1
- 3) Enter 4-digit Number

- Change the Auxiliary code

- 1) Enter Program mode
- 2) Press 2 to enter menu 1
- 3) Enter 4-digit Number

- Change the Program code

- 1) Enter Program mode
- 2) Press 3 to enter menu 1
- 3) Enter 4-digit Number

- Change the Secure code

- 1) Enter Program mode
- 2) Press 4 to enter menu 1

3) Enter 4-digit Number

- Change the Lock Strike Release Time and Tamper Siren Time

- 1) Press # for 2 seconds.
- 2) Enter the programme code.
- 3) Press 6.

4) You will now need to enter a 4 digit number. The first digit will tell the KA612 if it is to work with a fail safe or fail secure lock. The second digit represent the Tamper Sire Time, the last 2 digits will tell the KA612 how long it will keep the lock activated.

- > For the first digit:  
0 is for fail safe locks  
is for fail secure locks

- > For the second digit:  
Tamper Sire Time, enter any number from 1 to 9 mins

- > For the last 2 digits:

- 01= 1 second
- 99= 99 seconds

So if we want to set the lock activation time for 7 seconds and work with a fail secure lock we would set the 4 digits to 1007.

- Defining Auxiliary Inputs/Outputs

- 1) Press # for 2 seconds.
- 2) Enter the programme code.
- 3) Construct the 4-digit code using the instructions below:

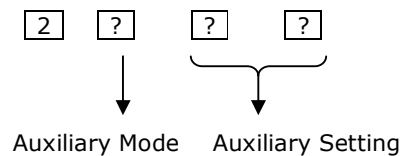

### Auxiliary Mode Quick Reference Guide

Auxiliary Mode	Auxiliary Input	Auxiliary Output Activated On	Aux. Relay	Auxiliary Settings (All times and delays are in seconds)
0	REX-2	Valid Code or REX-2	N.O.	01 to 99 Aux. Relay Release Time 00 Aux. Relay Toggles
1	Normal/Secure	Valid Code	N.O.	
2	Normal/Secure	Bell Button	N.O.	
3	Normal/Secure	Tamper Event	N.C.	01 to 99 Aux. Relay Release Time 00 Aux. Relay activated by Tamper
4	Normal/Secure	Direct Shunt	N.O.	00 to 99 Shunt Time
5	Door Monitor	Shunt	N.C.	00 to 99 Maximum Shunt Time

6	Door Monitor	Forced Door	N.C.	00 to 99 Forced Delay
7	Door Monitor	Door Ajar	N.C.	00 to 99 Ajar Delay

### Enrolling Primary & Secondary Codes

Two methods (Standard Method & Code Search Method):

Standard Method:

- Enrolling Primary Codes
  - 1) Enter the program mode
  - 2) Press 7
  - 3) Enter 3-digit user Number
  - 4) Enter 4-digit user Code or Present the Card
  
- Enrolling Secondary Codes(only when the user has his own Primary code)
  - 1) Enter the program mode
  - 2) Press 7
  - 3) Enter 3-digit user Number
  - 4) Enter 4-digit user Code or Present the Card

Code Search Method:

- 1) Enter the program mode
- 2) Press 8
- 3) Enter 3-digit user Number
- 4) Enter Primary Code
- 5) Enter program code to ensure

### Lock Strike and Auxiliary Relay Code Assignment

Two methods

- Standard Method:
  - 1) Enter the program mode
  - 2) Press 9
  - 3) Enter 3-digit user slot that you want to assign a code to
  - 4) Enter the assignment digit for the current User Slot
    - "1"assigns the Lock Strike Relay only
    - "2"number assigns the Auxiliary Strike Relay only
    - "3"assigns the Lock Strike and Auxiliary Relay
  
- Code Search Method:
  - 1) Enter the program mode
  - 2) Press 9
  - 3) Enter 000
  - 4) Present the EM Card or enter the 4-digit for the Current User

- Code Search Method:

Enrolling Secondary Codes(only when the user has his own Primary code)

- 1) Enter the program mode
- 2) Press 7
- 3) Enter 3-digit user Number
- 4) Enter Primary
- 5) Enter 4-digit user Code or Present the Card

- Deleting Primary & Secondary Codes

Two methods (Standard Method&Code Search Method):

Standard Method:

- 1) Enter the program mode
- 2) Press 8
- 3) Enter 3-digit user Number
- 4) Enter 4-digit user Code or Present the Card
- 5) Enter program code to ensure
  - "1"assigns the Lock Strike Relay only
  - "2"number assigns the Auxiliary Strike Relay only
  - "3"assigns the Lock Strike and Auxiliary Relay

### Return to Factory Default Settings

**warning:**

You must be very careful before using this command! Doing so will erase the entire memory which includes all User and Special Codes, and return all codes to their factory default settings.

- 1) Enter Programming Mode
- 2) Press 0 to enter Menu 0
- 3) Enter Programming Code to confirm

### Replacing a lost Program Code

**Note:** The KA612 must be in Normal Mode otherwise this will not work. Make sure that the Mode LED is green before proceeding.

- 1) Remove power from the KA612
- 2) Press the REX button
- 3) Apply power to the unit with REX button pressed
- 4) Release the REX button
- 5) You now have 15 seconds to program a new Program code into the unit using the initial default code 1-2-3-4, before the controller reverts to the existing code.

## Replacing a lost Secure Code

Note: The KA612 must be in Secure Mode otherwise this will not work. Make sure that the Mode LED is red before proceeding.

- 1) Remove power from the KA612
- 2) Press the REX Button
- 3) Apply power to the unit with REX button pressed
- 4) Release the REX Button
- 5) You now have 15 seconds to program a new Secure code  
4-digit Secure Code

into the unit using the initial default code 3-8-3-8, before the controller reverts to the existing code.

Operations:

- 1) Enter Default Secure Number 3-8-1-8
- 2) Enter # to return to Normal Mode
- 3) Press # for 2 seconds
- 4) Enter Default Programme Code 1-2-3-4
- 5) Press 4
- 6) Enter your new

## Appendix

Memorandum of Users

Contents	First change	Second change	Third change
Program code	1234		
Secure Code	3838		
Open code	2580		
Open Time	5s		

User name			
User Number			
User name			
User Number			
User Number			

## LED Display

Case	Mode LED		DOOR LED	
	Green	Red	Green	Red
Normal condition	Light			
Secure condition		Light		
Enter program ode			Light	
Release the Lock			Light	
Tamper				Light

Case	Sound display	Sound Description
Valid Press	One short deep	deep
Valid change code	Three short deeps	deep deep deep
Valid Reader	One short deep	deep
Invalid Code	One long deep	deep...
Invalid Program	One long deep	deep...

## Operation Glossary

First	Press # for 2 seconds Mode LED will turn down and Door LED will turn red						
Second	Enter programme code (default 1234) Mode LED will turn down and Door LED will turn green						
Third	Open Code (default 2580)	Aux Code (default 0852)	Program Code (default 1234)	Secure Code (default 1234)	Open delay time (default 4secs)	Enroll a new employee	Delete a employee
Eight choices	Press 1	Press 2	Press 3	Press 4	Press 6	Press 7	Press 8
	Enter your new 4-digit Code				Enter your new 4-digit Code	001-500 user NO.	Enter delete user NO.
					Two choices		
				1) 00xx 00=NO xx=01-99s*	Present Card or Enter 3-digits	Enter program code to confirm ok	

					2) 10yy 10=NC yy=01-99s*	Same as above or finish by pressing # key	
	Return to N-M after three deeps    M-L turn red    D-L turn down					Return to N-M after a deep	Return to N-M M-L turn green M-D turn down
Result	Set a new Open Code	Set a new Aux Code	Set a new Program Code	Set a new Secure Code	Set Open delay time	Enroll a new employee	Delete a employee

Note: M-L = Mode LED  
D-L= Door LED  
\* s= Seconds  
N-M= Normal Mode

www.best-china-security-supplies.com